



# STGD6NC60HD

## N-CHANNEL 6A - 600V DPAK Very Fast PowerMESH™ IGBT

TARGET SPECIFICATION

**Table 1: General Features**

TYPE	V <sub>CES</sub>	V <sub>CE(sat)</sub> (Max) @25°C	I <sub>C</sub> @100°C
STGD6NC60HDT4	600 V	< 2.5 V	6 A

- LOWER ON-VOLTAGE DROP (V<sub>cesat</sub>)
- OFF LOSSES INCLUDE TAIL CURRENT
- LOSSES INCLUDE DIODE RECOVERY ENERGY
- LOWER C<sub>RES</sub>/C<sub>IES</sub> RATIO
- HIGH FREQUENCY OPERATION
- VERY SOFT ULTRA FAST RECOVERY ANTI PARALLEL DIODE
- NEW GENERATION PRODUCTS WITH TIGHTER PARAMETER DISTRIBUTION

### DESCRIPTION

Using the latest high voltage technology based on a patented strip layout, STMicroelectronics has designed an advanced family of IGBTs, the PowerMESH™ IGBTs, with outstanding performances. The suffix "H" identifies a family optimized for high frequency applications in order to achieve very high switching performances (reduced t<sub>fall</sub>) maintaining a low voltage drop.

### APPLICATIONS

- HIGH FREQUENCY INVERTERS
- SMPS AND PFC IN BOTH HARD SWITCH AND RESONANT TOPOLOGIES
- MOTOR DRIVERS

**Table 2: Order Code**

PART NUMBER	MARKING	PACKAGE	PACKAGING
STGD6NC60HDT4	GD6NC60HD	DPAK	TAPE & REEL

**Figure 1: Package**

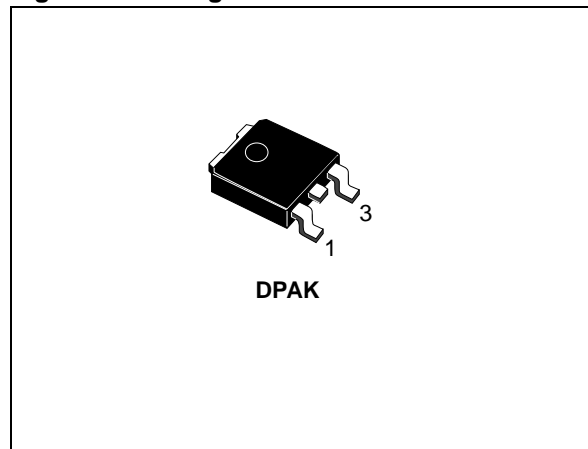

**Figure 2: Internal Schematic Diagram**

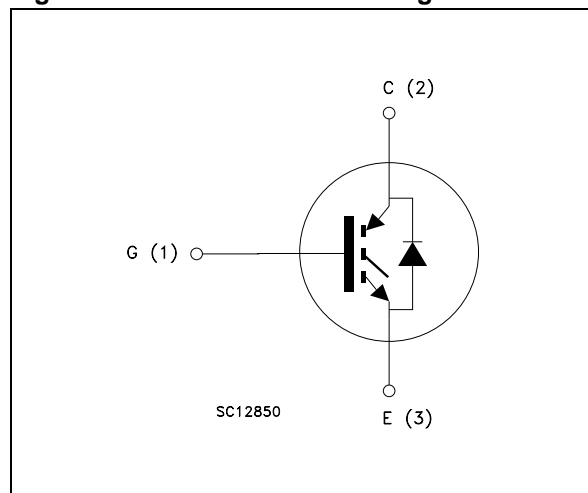

Rev. 1

**Table 3: Absolute Maximum ratings**

Symbol	Parameter	Value	Unit
V <sub>CES</sub>	Collector-Emitter Voltage (V <sub>GS</sub> = 0)	600	V
V <sub>ECR</sub>	Emitter-Collector Voltage	20	V
V <sub>GE</sub>	Gate-Emitter Voltage	±20	V
I <sub>C</sub>	Collector Current (continuous) at T <sub>C</sub> = 25°C (#)	10	A
I <sub>C</sub>	Collector Current (continuous) at T <sub>C</sub> = 100°C (#)	6	A
I <sub>CM</sub> (▣)	Collector Current (pulsed)	24	A
I <sub>F</sub>	Diode RMS Forward Current at T <sub>C</sub> = 25°C	TBD	A
P <sub>TOT</sub>	Total Dissipation at T <sub>C</sub> = 25°C	50	W
	Derating Factor	0.40	W/°C
T <sub>stg</sub>	Storage Temperature	- 55 to 150	°C
T <sub>j</sub>	Operating Junction Temperature		

(▣) Pulse width limited by max. junction temperature.

**Table 4: Thermal Data**

		Min.	Typ.	Max.	
R <sub>thj-case</sub>	Thermal Resistance Junction-case			2.5	°C/W
R <sub>thj-amb</sub>	Thermal Resistance Junction-ambient			100	°C/W
T <sub>L</sub>	Maximum Lead Temperature for Soldering Purpose (1.6 mm from case, for 10 sec.)		275		°C

**ELECTRICAL CHARACTERISTICS (T<sub>CASE</sub> =25°C UNLESS OTHERWISE SPECIFIED)**
**Table 5: Main Parameters**

Symbol	Parameter	Test Conditions	Min.	Typ.	Max.	Unit
V <sub>BR(CES)</sub>	Collector-Emitter Breakdown Voltage	I <sub>C</sub> = 1 mA, V <sub>GE</sub> = 0	600			V
I <sub>CES</sub>	Collector cut-off Current (V <sub>GE</sub> = 0)	V <sub>CE</sub> = Max Rating, T <sub>C</sub> = 25 °C V <sub>CE</sub> = Max Rating, T <sub>C</sub> = 125 °C			10 1	μA mA
I <sub>GES</sub>	Gate-Emitter Leakage Current (V <sub>CE</sub> = 0)	V <sub>GE</sub> = ± 20V, V <sub>CE</sub> = 0			±100	nA
V <sub>GE(th)</sub>	Gate Threshold Voltage	V <sub>CE</sub> = V <sub>GE</sub> , I <sub>C</sub> = 250 μA	3.75		5.75	V
V <sub>CE(sat)</sub>	Collector-Emitter Saturation Voltage	V <sub>GE</sub> = 15V, I <sub>C</sub> = 3 A V <sub>GE</sub> = 15V, I <sub>C</sub> = 3 A, T <sub>C</sub> = 125°C		1.9 1.7	2.5	V V

(#) Calculated according to the iterative formula:

$$I_C(T_C) = \frac{T_{JMAX} - T_C}{R_{THJ-C} \times V_{CESAT(MAX)}(T_C, I_C)}$$

## ELECTRICAL CHARACTERISTICS (CONTINUED)

Table 6: Dynamic

Symbol	Parameter	Test Conditions	Min.	Typ.	Max.	Unit
$g_{fs}$ (1)	Forward Transconductance	$V_{CE} = 15 \text{ V}$ , $I_C = 3 \text{ A}$		TBD		S
$C_{ies}$	Input Capacitance	$V_{CE} = 25 \text{ V}$ , $f = 1 \text{ MHz}$ , $V_{GE} = 0$		320		pF
$C_{oes}$	Output Capacitance			28		pF
$C_{res}$	Reverse Transfer Capacitance			7.2		pF
$Q_g$ $Q_{ge}$ $Q_{gc}$	Total Gate Charge Gate-Emitter Charge Gate-Collector Charge	$V_{CE} = 390 \text{ V}$ , $I_C = 3 \text{ A}$ , $V_{GE} = 15 \text{ V}$ (see Figure 5)		15 TBD TBD	TBD	nC nC nC
$I_{CL}$	Turn-Off SOA Minimum Current	$V_{clamp} = 480 \text{ V}$ , $T_j = 150^\circ\text{C}$ $R_G = 10 \Omega$ , $V_{GE} = 15 \text{ V}$	TBD			A

(1) Pulsed: Pulse duration= 300  $\mu\text{s}$ , duty cycle 1.5%

Table 7: Switching On

Symbol	Parameter	Test Conditions	Min.	Typ.	Max.	Unit
$t_{d(on)}$ $t_r$ ( $di/dt$ ) <sub>on</sub>	Turn-on Delay Time Current Rise Time Turn-on Current Slope	$V_{CC} = 390 \text{ V}$ , $I_C = 3 \text{ A}$ $R_G = 10 \Omega$ , $V_{GE} = 15\text{V}$ , $T_j = 25^\circ\text{C}$ (see Figure 3)		TBD TBD TBD		ns ns A/ $\mu\text{s}$
$t_{d(on)}$ $t_r$ ( $di/dt$ ) <sub>on</sub>	Turn-on Delay Time Current Rise Time Turn-on Current Slope	$V_{CC} = 390 \text{ V}$ , $I_C = 3 \text{ A}$ $R_G = 10 \Omega$ , $V_{GE} = 15\text{V}$ , $T_j = 125^\circ\text{C}$ (see Figure 3)		TBD TBD TBD		ns ns A/ $\mu\text{s}$

Table 8: Switching Off

Symbol	Parameter	Test Conditions	Min.	Typ.	Max.	Unit
$t_r(V_{off})$ $t_{d(off)}$ $t_f$	Off Voltage Rise Time Turn-off Delay Time Current Fall Time	$V_{CC} = 390 \text{ V}$ , $I_C = 3 \text{ A}$ , $R_G = 10 \Omega$ , $V_{GE} = 15 \text{ V}$ $T_j = 25^\circ\text{C}$ (see Figure 3)		TBD TBD 70		ns ns ns
$t_r(V_{off})$ $t_{d(off)}$ $t_f$	Off Voltage Rise Time Turn-off Delay Time Current Fall Time	$V_{CC} = 390 \text{ V}$ , $I_C = 3 \text{ A}$ , $R_G = 10 \Omega$ , $V_{GE} = 15 \text{ V}$ $T_j = 125^\circ\text{C}$ (see Figure 3)		TBD TBD TBD		ns ns ns

Table 9: Switching Energy

Symbol	Parameter	Test Conditions	Min.	Typ.	Max.	Unit
$E_{on}$ (2) $E_{off}$ (3) $E_{ts}$	Turn-on Switching Losses Turn-off Switching Loss Total Switching Loss	$V_{CC} = 390 \text{ V}$ , $I_C = 3 \text{ A}$ $R_G = 10 \Omega$ , $V_{GE} = 15\text{V}$ , $T_j = 25^\circ\text{C}$ (see Figure 3)		TBD TBD TBD		$\mu\text{J}$ $\mu\text{J}$ $\mu\text{J}$
$E_{on}$ (2) $E_{off}$ (3) $E_{ts}$	Turn-on Switching Losses Turn-off Switching Loss Total Switching Loss	$V_{CC} = 390 \text{ V}$ , $I_C = 3 \text{ A}$ $R_G = 10 \Omega$ , $V_{GE} = 15\text{V}$ , $T_j = 125^\circ\text{C}$ (see Figure 3)		TBD TBD TBD		$\mu\text{J}$ $\mu\text{J}$ $\mu\text{J}$

(2)  $E_{on}$  is the turn-on losses when a typical diode is used in the test circuit in figure 2. If the IGBT is offered in a package with a co-pack diode, the co-pack diode is used as external diode. IGBTs & DIODE are at the same temperature (25°C and 125°C)

(3) Turn-off losses include also the tail of the collector current.

Table 10: Collector-Emitter Diode

Symbol	Parameter	Test Condition	Min.	Typ.	Max.	Unit
$V_f$	Forward On-Voltage	$I_f = 1.5 \text{ A}$ $I_f = 1.5 \text{ A}, T_j = 125 \text{ }^\circ\text{C}$		1.6 1.3	2.1	V V
$t_{rr}$ $t_a$ $Q_{rr}$ $I_{rrm}$ $S$	Reverse Recovery Time Reverse Recovery Charge Reverse Recovery Current Softness factor of the diode	$I_f = 1.5 \text{ A}, V_R = 40 \text{ V},$ $T_j = 25 \text{ }^\circ\text{C}, di/dt = 100 \text{ A}/\mu\text{s}$ (see Figure 6)		TBD TBD TBD TBD TBD		ns ns nC A A
$t_{rr}$ $t_a$ $Q_{rr}$ $I_{rrm}$ $S$	Reverse Recovery Time Reverse Recovery Charge Reverse Recovery Current Softness factor of the diode	$I_f = 1.5 \text{ A}, V_R = 40 \text{ V},$ $T_j = 125 \text{ }^\circ\text{C}, di/dt = 100 \text{ A}/\mu\text{s}$ (see Figure 6)		TBD TBD TBD TBD TBD		ns ns nC A A

Figure 3: Test Circuit for Inductive Load Switching

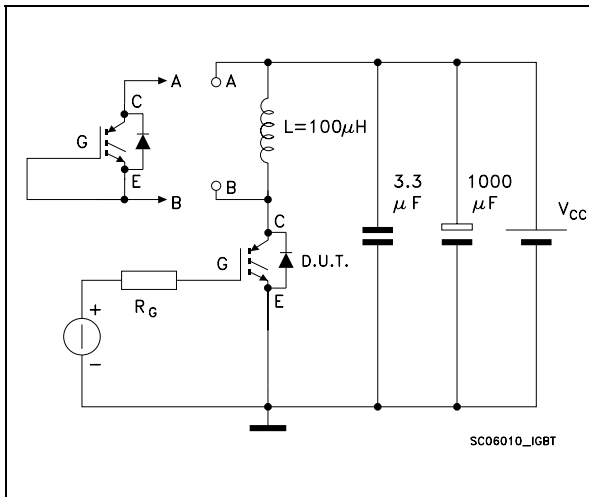

Figure 4: Switching Waveforms

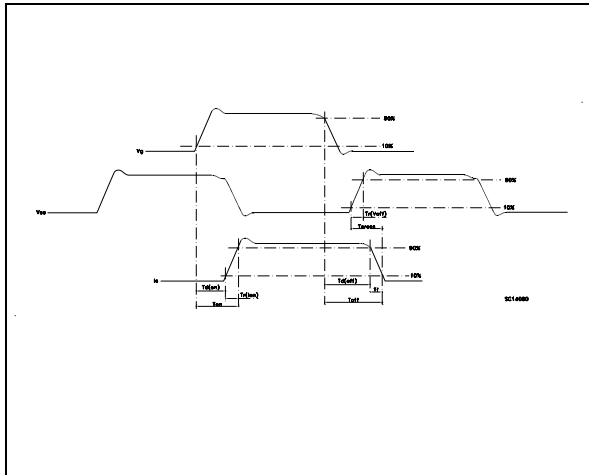

Figure 5: Gate Charge Test Circuit

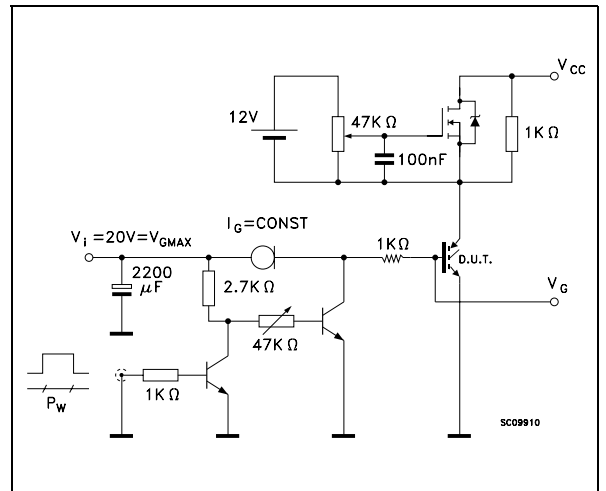
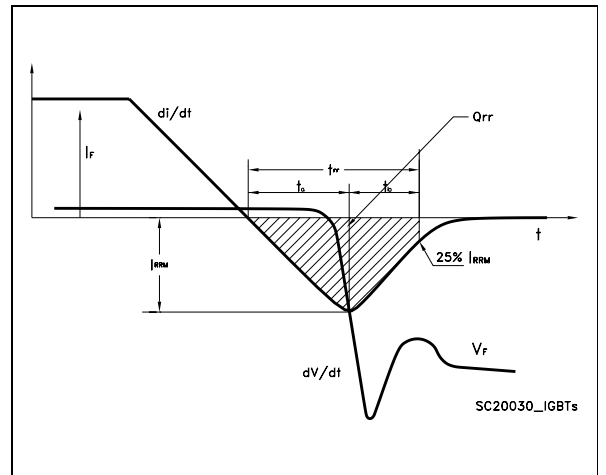
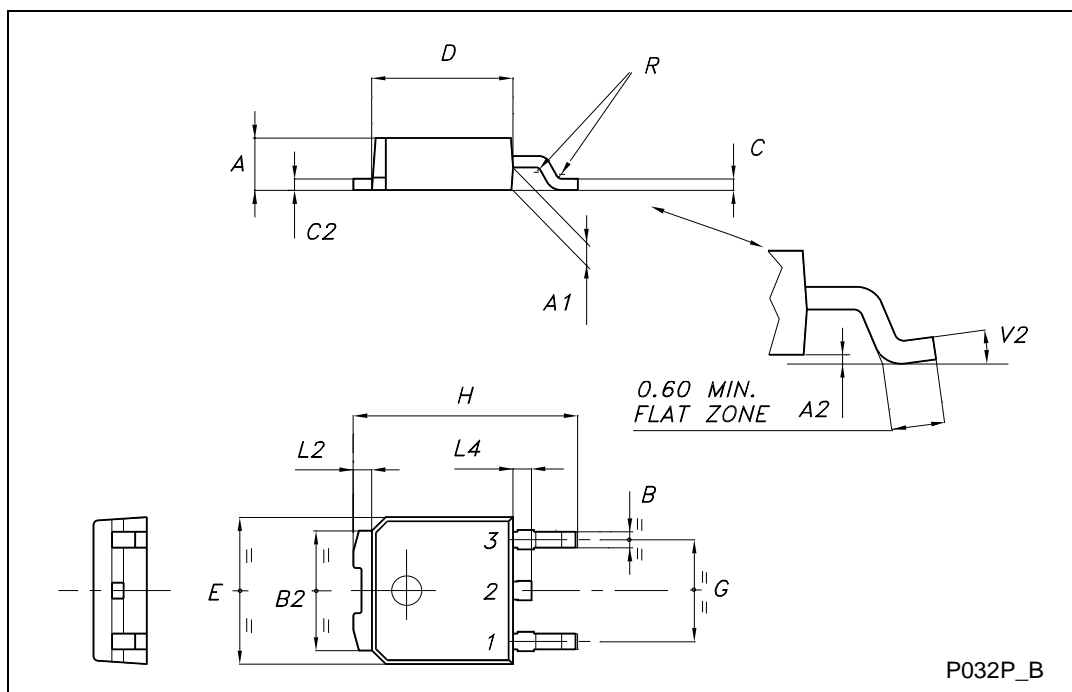

Figure 6: Diode Recovery Time Waveforms



TO-252 (DPAK) MECHANICAL DATA

DIM.	mm			inch		
	MIN.	TYP.	MAX.	MIN.	TYP.	MAX.
A	2.20		2.40	0.087		0.094
A1	0.90		1.10	0.035		0.043
A2	0.03		0.23	0.001		0.009
B	0.64		0.90	0.025		0.035
B2	5.20		5.40	0.204		0.213
C	0.45		0.60	0.018		0.024
C2	0.48		0.60	0.019		0.024
D	6.00		6.20	0.236		0.244
E	6.40		6.60	0.252		0.260
G	4.40		4.60	0.173		0.181
H	9.35		10.10	0.368		0.398
L2		0.8			0.031	
L4	0.60		1.00	0.024		0.039
V2	0°		8°	0°		0°



**DPAK FOOTPRINT**

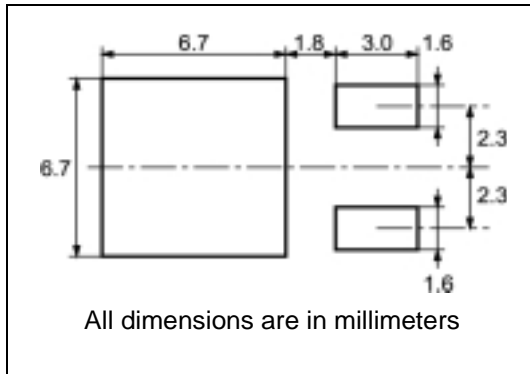

**TAPE AND REEL SHIPMENT**

**REEL MECHANICAL DATA**

DIM.	mm		inch	
	MIN.	MAX.	MIN.	MAX.
A		330		12.992
B	1.5		0.059	
C	12.8	13.2	0.504	0.520
D	20.2		0.795	
G	16.4	18.4	0.645	0.724
N	50		1.968	
T		22.4		0.881

BASE QTY	BULK QTY
2500	2500

**TAPE MECHANICAL DATA**

DIM.	mm		inch	
	MIN.	MAX.	MIN.	MAX.
A0	6.8	7	0.267	0.275
B0	10.4	10.6	0.409	0.417
B1		12.1		0.476
D	1.5	1.6	0.059	0.063
D1	1.5		0.059	
E	1.65	1.85	0.065	0.073
F	7.4	7.6	0.291	0.299
K0	2.55	2.75	0.100	0.108
P0	3.9	4.1	0.153	0.161
P1	7.9	8.1	0.311	0.319
P2	1.9	2.1	0.075	0.082
R	40		1.574	
W	15.7	16.3	0.618	0.641

**Table 11: Revision History**

<b>Date</b>	<b>Revision</b>	<b>Description of Changes</b>
14-Jun-2005	1	First release



Information furnished is believed to be accurate and reliable. However, STMicroelectronics assumes no responsibility for the consequences of use of such information nor for any infringement of patents or other rights of third parties which may result from its use. No license is granted by implication or otherwise under any patent or patent rights of STMicroelectronics. Specifications mentioned in this publication are subject to change without notice. This publication supersedes and replaces all information previously supplied. STMicroelectronics products are not authorized for use as critical components in life support devices or systems without express written approval of STMicroelectronics.

The ST logo is a registered trademark of STMicroelectronics

All other names are the property of their respective owners

© 2005 STMicroelectronics - All Rights Reserved

STMicroelectronics group of companies

Australia - Belgium - Brazil - Canada - China - Czech Republic - Finland - France - Germany - Hong Kong - India - Israel - Italy - Japan - Malaysia - Malta - Morocco - Singapore - Spain - Sweden - Switzerland - United Kingdom - United States of America